

CONCIOUS HANDLING

make the difference

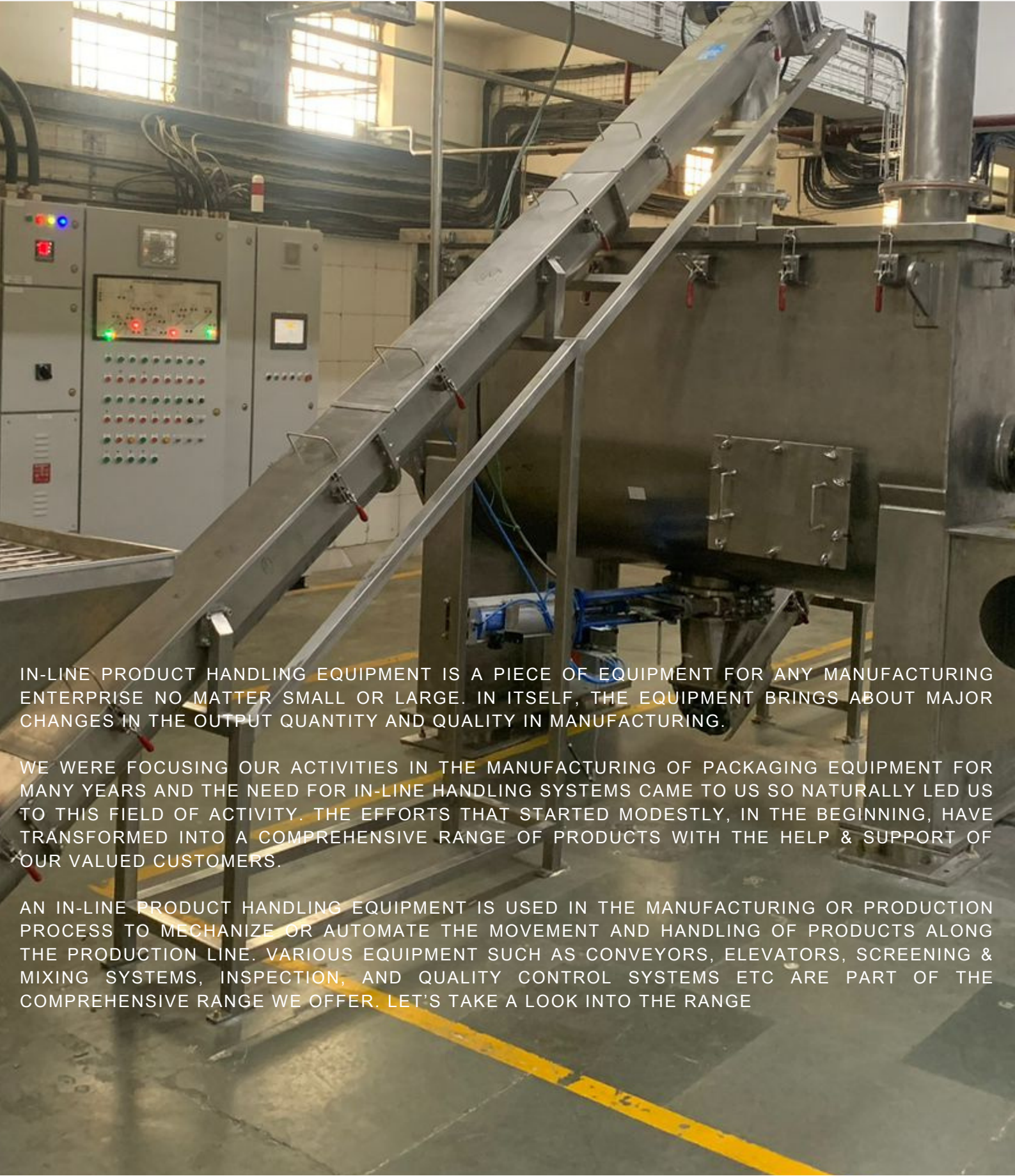

IN-LINE PRODUCT HANDLING EQUIPMENT IS A PIECE OF EQUIPMENT FOR ANY MANUFACTURING ENTERPRISE NO MATTER SMALL OR LARGE. IN ITSELF, THE EQUIPMENT BRINGS ABOUT MAJOR CHANGES IN THE OUTPUT QUANTITY AND QUALITY IN MANUFACTURING.

WE WERE FOCUSING OUR ACTIVITIES IN THE MANUFACTURING OF PACKAGING EQUIPMENT FOR MANY YEARS AND THE NEED FOR IN-LINE HANDLING SYSTEMS CAME TO US SO NATURALLY LED US TO THIS FIELD OF ACTIVITY. THE EFFORTS THAT STARTED MODESTLY, IN THE BEGINNING, HAVE TRANSFORMED INTO A COMPREHENSIVE RANGE OF PRODUCTS WITH THE HELP & SUPPORT OF OUR VALUED CUSTOMERS.

AN IN-LINE PRODUCT HANDLING EQUIPMENT IS USED IN THE MANUFACTURING OR PRODUCTION PROCESS TO MECHANIZE OR AUTOMATE THE MOVEMENT AND HANDLING OF PRODUCTS ALONG THE PRODUCTION LINE. VARIOUS EQUIPMENT SUCH AS CONVEYORS, ELEVATORS, SCREENING & MIXING SYSTEMS, INSPECTION, AND QUALITY CONTROL SYSTEMS ETC ARE PART OF THE COMPREHENSIVE RANGE WE OFFER. LET'S TAKE A LOOK INTO THE RANGE

CONVEYORS ELEVATORS



1. Belt conveyors – Simple belt conveyors with and without side walls
2. Slant Elevators / Inclined Elevators – Are belt elevators with horizontal cleats to transport products on a slope or inclination to a higher platform.
3. Z type elevators – Belt elevators moving products on a slope with horizontal arms at input and/or output.
4. Vertical Bucket Elevators – Our non-scooping type of vertical bucket elevators are versatile in safe transportation of products using low floor footprint available in different throughput capacities.
5. Roller conveyors – Gravity driven roller conveyors are offered
6. Screw Elevators / Screw conveyors: Offers closed and open type screw elevators/conveyors suitable for movement of powdered products.
7. Modular conveyors / Elevators - Suitable for Wet Applications

SORTING MIXING



1. Screening - We offer circular vibro screens in different sizes and multiple deck options with and without anti-blinding systems. Rectangular vibratory screens are also available.
2. Blending systems: Conical blenders as well as Ribbon blenders and offered in different capacities.

INSPECTION QUALITY CONTROL

1. Inspection belts – Offered to facilitate manual visual inspection & separation of contaminants/sorting
2. Metal detectors – Offered in belt mounted, Gravity feed, Standalone models
3. Magnets: Plate magnets and magnetic grills are offered.

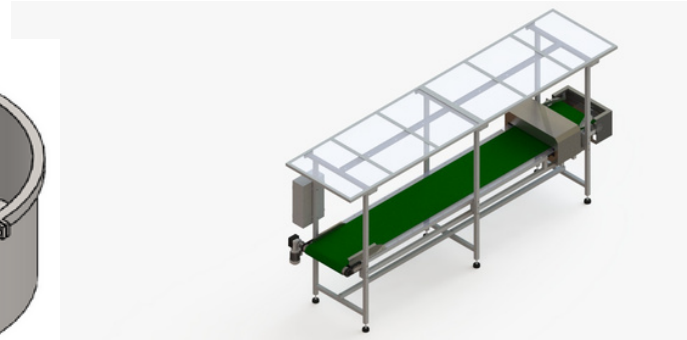
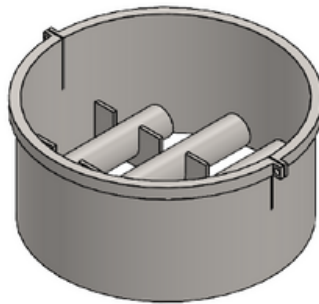

FOR DETAILS CONTACT

+91 484 2727500

+91 9387496567

Email : sepack@sepack.in/gk@sepack.in